

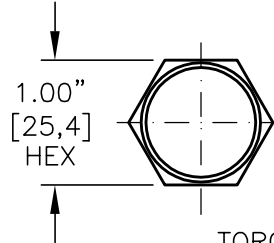

FLOW DIVIDER/COMBINER VALVE, SPOOL TYPE

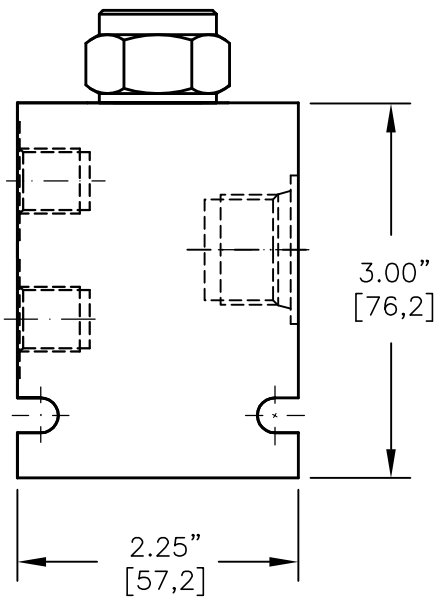

TORQUE to 35/40 Ft-Lb.
[47/54 N-m].

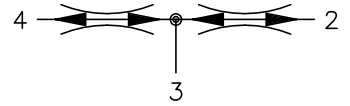
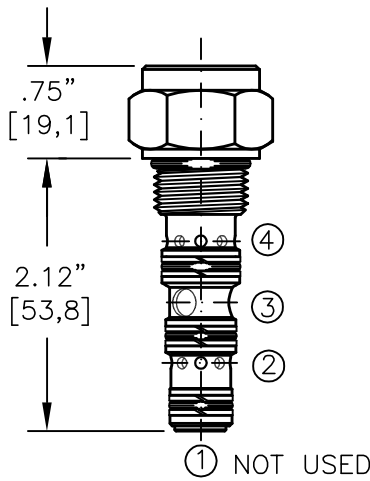

① NOT USED

PORT #3 (INLET) IS ONE SIZE LARGER THAN PORTS #2 & #4 (OUTLET).
FOR ALUMINUM OR STEEL VALVE HOUSING CONFIGURATIONS SEE PAGE 0-041.2

FDCV-08-X-X-XX

- BASIC _____
- SIZE _____
- 08 = 3/4"-16 UNF
- SEALS _____
- N = BUNA "N"
- V = VITON
- PORT #3 _____
- 0 = CARTRIDGE ONLY
- 03BX = G 3/8" BSPP
- 08TX = SAE - #8
- "A" - ALUM. HOUSING
- "S" - STEEL HOUSING

FLOW DIVISION

CODE	PORT#2	PORT#4	MAX FLOW
11	50%	50%	1.0 GPM
22	50%	50%	2.0 GPM
33	50%	50%	3.0 GPM
44	50%	50%	4.0 GPM
66	50%	50%	6.0 GPM
88	50%	50%	8.0 GPM
12	33.3%	66.6%	1.5 GPM
13	25%	75%	2.0 GPM
24	33.3%	66.6%	3.0 GPM
26	25%	75%	4.0 GPM
36	33.3%	66.6%	4.5 GPM
48	33.3%	66.6%	6.0 GPM
21	66.6%	33.3%	1.5 GPM
31	75%	25%	2.0 GPM
42	66.6%	33.3%	3.0 GPM
62	75%	25%	4.0 GPM
63	66.6%	33.3%	4.5 GPM
84	66.6%	33.3%	6.0 GPM

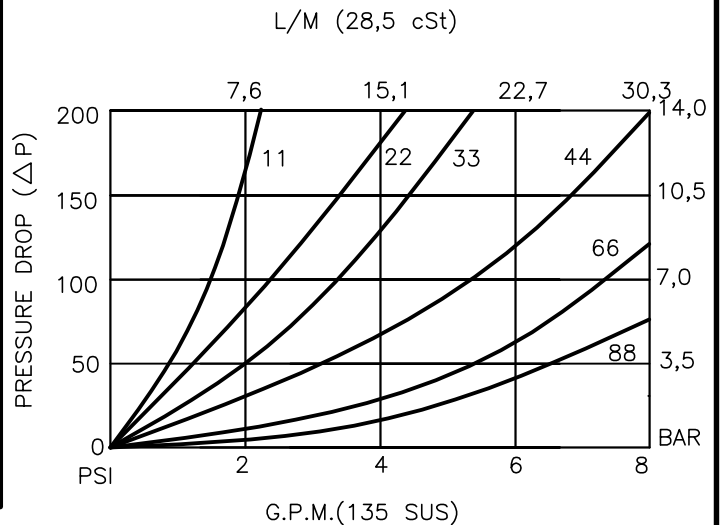



FLOW DIVIDER/COMBINER VALVE, SPOOL TYPE

DESCRIPTION

This unit is a spool type, screw in cartridge style, flow divider/combiner valve.

OPERATIONS

This valve divides flow from port 3 to ports 2 and 4 and combines flow from ports 2 and 4 to port 3 at the specified flow division regardless of load or system pressure.

Should the circuit operation result in blockage of either port 2 or 4, the opposite port will continue to flow but at a reduced flow rate to synchronize a cylinder.

FEATURES AND BENEFITS

Flow accuracy dividing or combining:

+/-5.0% of flows under 40% of the rated flow.

+/-2.5% of flows over 40% of the rated flow.

Quiet and stable operation over wide varying flow, pressure and temperature range.

All external carbon steel parts are plated for longer life against the elements.

All cartridge valves are 100% functionally tested.

Industry common cavity.

SPECIFICATIONS

OPERATING PRESSURE: 5,000 PSI [350 Bar]

PROOF PRESSURE: 10,000 PSI [700 Bar]

FLOW: 8.0 GPM [30 l/m] nominal. See performance chart.

VALVE HOUSINGS: 2500 PSI [175 Bar] = Aluminum - Anodized.

5000 PSI [350 Bar] = Steel - Unplated.

OPERATING TEMPERATURE: -40° to +250° F. [-40° to +120° C.]

OPERATING MEDIA: All general purpose hydraulic fluids such as

MIL-H-5606, SAE-#10, SAE-#20, etc.

INSTALLATION: No restrictions.

SEAL KIT: SKN-0842 Buna "N".

SKV-0842 Viton.

WEIGHT: .24 lb [.11 kg] cartridge only.

VALVE CAVITY: #C0840, See Page 0-041.0.